

Direct Production of Functional Matrix Metalloproteinase—14 Without Refolding or Activation and Its Application for In Vitro Inhibition Assays

Dong Hyun Nam, Xin Ge

Department of Chemical and Environmental Engineering, University of California, 900 University Ave Riverside, Riverside 92521, California; telephone: +1-951-827-6229; fax: +1-951- 827-5696; e-mail: xge@engr.ucr.edu

ABSTRACT: Human matrix metalloproteinase (MMP)-14, a membrane-bound zinc endopeptidase, is one of the most important cancer targets because it plays central roles in tumor growth and invasion. Large amounts of active MMP-14 are required for cancer research and the development of chemical or biological MMP-14 inhibitors. Current methods of MMP-14 production through refolding and activation are labor-intensive, time-consuming, and often associated with low recovery rates, lot-to-lot variation and heterogeneous products. Here, we report direct production of the catalytic domain of MMP-14 in the periplasmic space of *Escherichia coli*. 0.5 mg/L of functional MMP-14 was produced without tedious refolding or problematic activation process. MMP-14 prepared by simple periplasmic treatment can be readily utilized to evaluate the potencies of chemical and antibody-based inhibitors. Furthermore, co-expression of both MMP-14 and antibody Fab fragments in the periplasm facilitated inhibitory antibody screening by avoiding purification of MMP-14 or Fabs. We expect this MMP-14 expression strategy can expedite the development of therapeutic drugs targeting MMPs with biological significance.

Biotechnol. Bioeng. 2016;113: 717–723.

© 2015 Wiley Periodicals, Inc.

KEYWORDS: MMP; periplasmic expression; inhibitory antibody

Introduction

Beyond simple protein degradation, proteases are important signaling molecules and mediate many physiological processes (Cal and López-Otín, 2015; Fernández and López-Otín, 2015; López-Otín and Matrisian, 2007; Quirós et al., 2015). Imbalanced

protease activities are therefore often associated with pathological states such as cancer (Turk, 2006), neuropathic pain (Choi et al., 2012), chronic wound (Tregove et al., 1999), hypertension (Dusing and Sellers, 2009), and inflammation diseases (Page-McCaw et al., 2007). Particularly, certain matrix metalloproteinases (MMPs) confer cells with the ability to remodel and penetrate extracellular matrix (ECM) and participate in all aspects of cancer progression, i.e., regulation of tumor cell migration, invasion, angiogenesis, and induction of intracellular signaling pathways (Jiang et al., 2001; Lehti et al., 2000; Seiki, 2003; Wang et al., 2004). While most MMPs are secreted, MMP-14 or membrane type-1 MMP (MT1-MMP) belongs to a subfamily of MMPs that is associated with the membrane. The elevated level of MMP-14 often correlates with poor prognosis of cancer – lymph node metastases, large tumor size, and cancer progression from benign to highly invasive stages (Jiang et al., 2001; Mimori et al., 2001; Tetu et al., 2006). Taking these preclinical and clinical evidences together, MMP-14 has been considered as an important regulatory enzyme for cancer research and a predominant therapeutic target for cancer treatments (Devv and Dransfield, 2011; Genís et al., 2006; Morrison et al., 2009). Therefore, consistent supply of active human MMP-14 at mg scales is essential for cancer biology research and for the developments of novel diagnostic and therapeutic agents, e.g., identification of physiological substrates of MMP-14, characterization of ECM remodeling *in vitro* and *in vivo*, and screening for highly selective MMP inhibitors for cancer treatment.

MMPs are multidomain zinc-dependent endopeptidases that share a basic structural organization comprising propeptidic, catalytic, hinge, and hemopexin like domains (Sela-Passwell et al., 2010). In the human body, MMP-14 is synthesized as an inactive ~60 kD zymogen form in which a conserved cystein switch residue in pro-peptide region binds to the catalytic zinc ion of the active site (Fig. 1A). A furin-like convertase, which cleaves at the RRKR motif located between the pro-peptide and the catalytic domain, activates MMP-14. Activated MMP-14, starting at Tyr112, is then transported to the plasma membrane facing the extracellular space where it cleaves pericellular substrates. Overexpression of recombinant human MMP-14 catalytic and hinge domains

Correspondence to: X. Ge

Contract grant sponsor: NSF

Contract grant number: CBET 1453645

Contract grant sponsor: UC Cancer Research Coordinating Committee

Received 8 June 2015; Revision received 5 September 2015; Accepted 21 September 2015

Accepted manuscript online 29 September 2015;

Article first published online 7 October 2015 in Wiley Online Library

(<http://onlinelibrary.wiley.com/doi/10.1002/bit.25840/abstract>).

DOI 10.1002/bit.25840

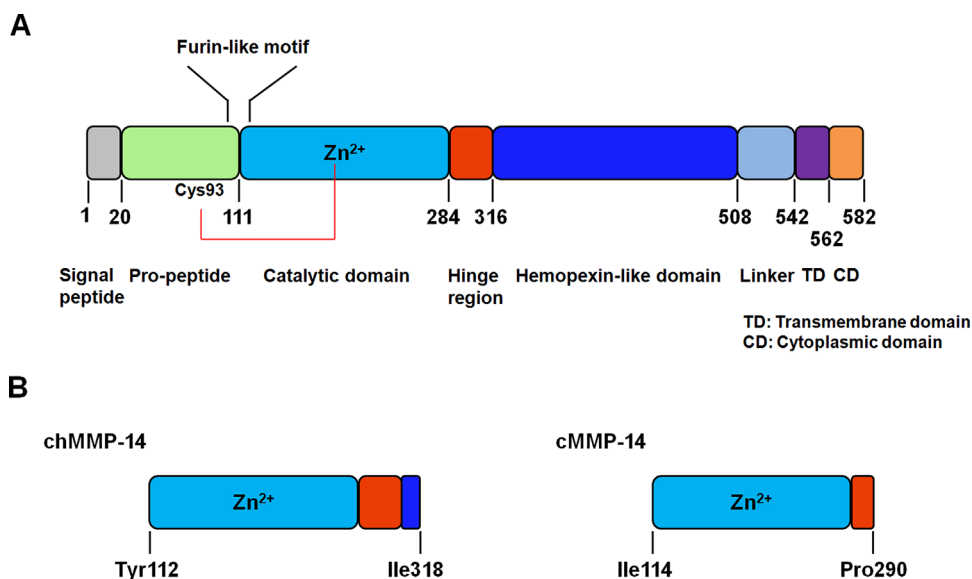

Figure 1. Schematics of MMP-14 domain structures. (A) Full length MMP-14. Cys93 of pro-peptide binds the catalytic Zn^{2+} in the active site to maintain its zymogen form. (B) MMP-14 catalytic domain structures periplasmically expressed in this study. Left: chMMP-14, Tyr112-Ile318. Right: cMMP-14, Ile114-Pro290. Note, MMP-14 has no disulfide bonds.

(chMMP-14) in *E. coli* resulted in the formation of inclusion bodies exclusively (Koo et al., 2002; Lichte et al., 1996; Udi et al., 2013). After solubilization and purification, the denatured chMMP-14 was refolded to its active form via multiple steps of gradient dialysis, which were often labor-extensive and time-consuming (3–5 days). Besides uncontrollable lot-to-lot variation, during the refolding process, autoproteolysis occurred at both termini with various degrees thus generating heterogeneous mixtures (Lichte et al., 1996). Alternatively, recombinant proteins can be targeted to the periplasm of gram-negative bacteria by fusing with signal peptides (e.g., PelB, OmpA, MalE, and PhoA for *E. coli*). In addition to providing an oxidative environment that facilitates the formation of disulfide bonds, periplasmic expression can enhance proper protein folding due to multiple molecular chaperons (e.g., SurA, PpiA, PpiD, FkpA, and Skp) (Baneyx and Mujacic, 2004) and a slow processing rate controlled by secretion machineries (Wülfing and Plückthun, 1994). Following successful overexpression of T cell receptor fragments in *E. coli* periplasm (Ward, 1992), many recombinant proteins such as antibody fragments and bacterial, viral and mammalian proteases have been periplasmically produced (Babé et al., 2000; Frenzel et al., 2013; Harvey et al., 2004; Makino et al., 2011; Sroga and Dordick, 2002). In most of these studies, the mammalian proteases were expressed as pro-enzymes or fused with DsbC, GST, or OmpT leader sequence, and therefore additional steps were needed for activation or fusion partner removal (Babé et al., 2000). Previously, human MMP-14 with its propeptidic domain (Pro-MMP-14) has been periplasmically expressed, followed by chromatographic purification and treatments with 4-aminophenylmercuric acetate (APMA) or trypsin to yield the functional enzyme (Will et al., 1996). However, as an organomercury compound APMA is toxic and thus not suitable for cell-based or animal studies, and complete

activation of pro-MMP-14 using APMA is difficult to achieve (Knäuper et al., 1996). Trypsin treatment also digests the C-terminus of MMP-14 at the putative furin cleavage site (RRKR/YAIQ) resulting in truncated products (Will et al., 1996). To avoid these tedious refolding and problematic activation processes, this study reports a novel approach to the production of functional MMP-14 (MMP-14) by directly expressing MMP-14 catalytic domain in the periplasmic space of *E. coli* (Fig. 1B). The periplasmically expressed MMP-14 can be readily applied for evaluation of chemical and biological inhibitors and rapid identification of inhibitory antibodies without purification of MMP-14 or antibodies (Fig. 2). We expect this novel cMMP-14 expression strategy can expedite MMP related research especially the development of therapeutic drugs targeting MMPs that are important for cancer progression.

Materials and Methods

Cloning and Expression of Human MMP-14 Catalytic Domain

The DNA fragments encoding the catalytic and hinge domains of human MMP-14 (chMMP-14, Tyr112-Ile318) and matured MMP-14 catalytic domain (cMMP-14, Ile114-Pro290) were assembled and amplified from synthetic oligonucleotides by PCR (Fig. 1B). The obtained chMMP-14 and cMMP-14 fragments were cloned into *Sfi*I sites of pMopac16 (Hayhurst et al., 2003) to generate pMopac16-chMMP14/cMMP14. Transformed *E. coli* Jude-I cells [(DH10B F':Tn10 (Tet^r)] were grown in 2×YT media supplemented with 35 μg/mL chloramphenicol (2×YT/Chlor) at 30°C to reach 0.6–1.0 OD₆₀₀, then 0–1 mM IPTG was added to induce chMMP-14/cMMP-14 expression overnight at 30°C. For co-expression

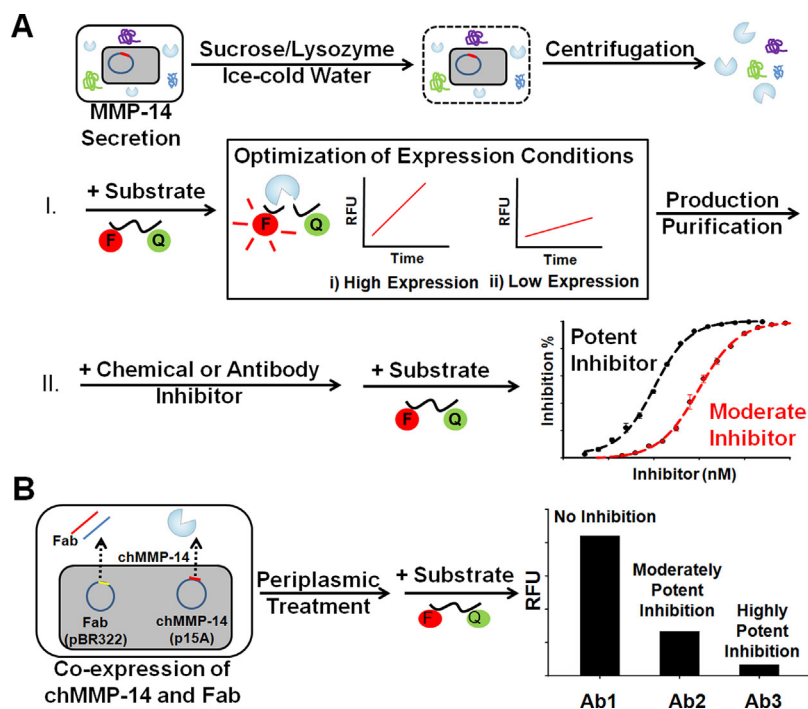

Figure 2. Periplasmic expression of functional MMP-14 catalytic domain and its applications on inhibitory assay development. (A) Periplasmic treatment followed by (I) optimization of expression conditions to achieve high yields of active cMMP-14 without refolding or activation; and (II) semi-quantitative IC_{50} measurements of chemical or antibody inhibitors. (B) Periplasmic co-expression of chMMP-14 and Fabs to identify inhibitory antibodies without protein purification.

of MMP-14 with Fab antibodies, the p15A origin of pBAD33 was amplified (using primers 5'-ctagcgcctaggccgcaaacgctt-3', and 5'-ctagcgcctcagtgattaataagatgctcttggagatcgttttggctg-3') and ligated with chMMP-14/cMMP-14 fragments (amplified from pMopac16-chMMP14/cMMP14 using primers 5'-ctagcgcctcagagaacgccagcaacgctg-3', and 5'-ctagcgcctagggaagatcctttgacttttctacgggt-3') at *AvrI/XhoI* sites to construct pMopac16(p15A)-chMMP14/-cMMP14. Double transformed Jude-I cells containing pMopac16(p15A)-chMMP14/-cMMP14 and Fab expression plasmid carrying a PhoA promoter and a pBR322 origin were cultured at 30°C overnight in 2×YT media supplemented with 100 μg/mL ampicillin and 35 μg/mL chloramphenicol (2×YT/Chlor/Amp) without IPTG to co-express both MMP-14 and Fab antibodies in the periplasmic space.

Refolding of Human chMMP-14 and Activity Assay

As the standard to evaluate the quality of periplasmically produced MMP-14, chMMP-14 was also cytoplasmically expressed, purified, and refolded as previously described (Koo et al., 2002; Nam and Ge, 2013; Udi et al., 2013). Typically, 250 mL culture yielded 5 mg purified chMMP-14 and ~35% refolding efficiency was achieved. Activities of refolded chMMP-14 were measured using XV peptide (QXLTM-520-γ-Abu-Pro-Gln-Gly-Leu-Dab(5-FAM)-Ala-Lys-H₂; AnaSpec, Inc., San Jose, CA). Fluorescent signals (RFU) with excitation at 490 nm and emission at 520 nm were monitored using Synergy H4 hybrid Multi-Mode Microplate Reader (BioTek, San Diego, CA).

Periplasmic Fractions Preparation and FRET Inhibition Assay

The cells harboring human chMMP-14 or cMMP-14 gene were cultured in 5 mL 2×YT/Chlor at 30°C overnight in the absence of IPTG to maximize expression level. After OD₆₀₀ measurements and normalization, 3 mL cell cultures of OD = 1 (or 3 OD hereafter) were pelleted and resuspended in 100 μL of periplasmic buffer (200 mM Tris/HCl, pH 7.5; 20% sucrose; 30 U/μL lysozyme) for incubation at room temperature for 5 min. The samples were then treated by osmotic shock with 100 μL ice-cold ddH₂O followed by incubation on ice for 10 min. After centrifugation at 13,000g for 2 min, clarified supernatants were transferred into 96-well black assay plates (Corning, Inc., Corning, NY). In FRET assays, the reactions started by addition of 1 μM XV peptide substrate to periplasmic fractions and fluorescent signals were recorded for the duration of the experiments. High potency MMP inhibitor GM6001 (EMD Millipore, Corp., Chicago, IL) was used to titrate the amounts of chMMP-14/cMMP-14 produced. For IC_{50} estimation, purified antibody Fab fragments DX-2400, 3A2, 3D9, and 3B10 and chemical inhibitor acetohydroxamic acid (AHA) and GM6001 were serially diluted and incubated with periplasmic fractions containing 1 nM (for antibodies) or 10 nM (for chemical inhibitors) cMMP-14 at room temperature for 20 min. 1 μM XV peptide was then added to start the reaction and initial velocities were monitored to generate IC_{50} curves.

Large-Scale Production of Human cMMP-14

Overnight culture of Jude-I cells carrying pMopac16-cMMP14 was inoculated into 500 mL 2×YT/Chlor at 30°C for 16 h without addition of IPTG. The cells were harvested and treated with osmotic shocks to recover periplasmic fraction as described above (Goldman et al., 2003). The cMMP-14 present in the periplasmic preparation was purified by affinity chromatography using anti-FLAG resin and elution with FLAG peptide following manufacturer's manual (Sigma–Aldrich, St. Louis, MO). The homogeneity of purified human cMMP-14 was verified by SDS-PAGE. After overnight dialysis to remove residual peptides, cMMP-14 concentrations were measured with NanoDrop 2000 (Thermo Scientific, Waltham, MA).

Results

Production of Fully Active Human MMP-14 Catalytic Domain by Periplasmic Expression

Human MMP-14 was typically expressed in the cytoplasm of *E. coli* as the inclusion body and processed by tedious refolding and activation steps, which often resulted in heterogeneous products. In contrast, we aim to directly produce functional human MMP-14 in periplasmic space without refolding or activation, given that the secretion and folding machineries of periplasm can improve expression quality (Baneyx and Mujacic, 2004; Wülfing and Plückthun, 1994). Previous studies indicated that during refolding, catalytic–hinge domain of human MMP-14 (chMMP-14, Tyr112-Ile318) was autoproteolyzed to its matured form (cMMP-14, Ile114-Pro290) (Koo et al., 2002; Lichte et al., 1996). Therefore, both chMMP-14 and cMMP-14 are subjected to characterize and compare their periplasmic expression profiles in our study (Fig. 1B). Genes of chMMP-14 (Tyr112-Ile318) and cMMP-14 (Ile114-Pro290) were cloned into a periplasmic expression vector carrying a *lac* promoter, a *pelB* leader, and a FLAG tag at C-terminus for detection and purification. After transformation into *E. coli* Jude-I cells and expression with 0.5 mM IPTG induction, the activities of MMP-14 in periplasmic fractions were directly monitored by adding a FRET peptide substrate. No EDTA was used in treatment due to its ability to chelate with Ca^{2+} and Zn^{2+} which are essential for structural integrity and catalytic function of MMPs (Fernandez-Catalan et al., 1998). As results shown in Figure 3A, periplasmic fractions of both chMMP-14 and cMMP-14 clones exhibited strong enzymatic activities of MMP-14 by cleaving the peptide substrate. The control clone without transformation did not display any detectable increase of fluorescent signal, indicating that the cleavage shown in MMP-14 samples were not mediated by native proteolytic enzymes present in *E. coli* periplasm. Using same amount of cultured cells (equivalent to 3 mL cell culture at $\text{OD}_{600} = 1$, or 3OD hereafter), mature cMMP-14 gave a reaction rate of 184 $\Delta\text{RFU}/\text{min}$, which was ~ 1.7 -fold higher than that of immature chMMP-14 (107 $\Delta\text{RFU}/\text{min}$).

The concentration of IPTG was next optimized to improve periplasmic expression level of cMMP-14. When IPTG concentration increased from 0.1 to 1 mM, MMP-14 activity increased

$\sim 72\%$ from 184 to 317 $\Delta\text{RFU}/\text{min}$ (Fig. 3B). However, in absence of IPTG, periplasmic fraction showed the highest activity of 691 $\Delta\text{RFU}/\text{min}$, which was ~ 2.2 folds higher than that of 1 mM IPTG (Fig. 3B). This increase of MMP-14 activity level in absence of inducer was presumably caused by the slow expression/secretion rate through the leaky *lac* promoter and hence decreased translation and folding load. The phenomenon that low induction level can improve the periplasmic expression quality is consistent with the experiment results of single chain T cell receptors (scTCRs)—yields of scTCRs in *E. coli* periplasm increased considerable without IPTG (Gunnarsen et al., 2010).

To minimize possible *in vivo* degradation of synthesized cMMP-14 and to study the effects of culture temperature on cMMP-14 production, protease-deficient strain BL21 was compared with Jude-I for cMMP-14 expression at room temperature (RT) or 30°C. Periplasmic fractions were prepared and subjected to western blot and FRET measurements. When cultured at RT, western blot analysis of both BL21 and Jude-I samples exhibited two strong bands, likely associated with processed cMMP-14 without the leader peptide *pelB* (20 kD) and unprocessed cMMP-14 with *pelB* (25 kD). When cultured at 30°C, the bands of unprocessed cMMP-14 became much fainter, suggesting that the majority of secreted cMMP-14 was properly processed at this temperature (Fig. 3C). Further FRET measurements using 3OD normalized cells cultured at 30°C indicated that the activity of Jude-I periplasmic samples (687 $\Delta\text{RFU}/\text{min}$) was >2.3 -fold higher than that of BL21 (305 $\Delta\text{RFU}/\text{min}$). Because similar expression levels were observed in western blot, this activity improvement could be attributed to more efficient protein folding in the appropriate host. In addition to plasmid stability, as a K12 strain, Jude-I has a slower protein synthesis rate compared to B strains (e.g., BL21), presumably resulting in a better protein folding and production of active cMMP-14 (Durfée et al., 2008; Gunnarsen et al., 2010).

Using optimized expression conditions, human cMMP-14 was expressed and purified from periplasmic fractions using anti-FLAG resin. One of the most important aspects of this method is that it does not require denature, refolding, or activation, and thus greatly simplified the procedure. SDS–PAGE analysis of purified cMMP-14 indicated a single band of processed cMMP-14 (20 kD, Fig. 4 inset), while unprocessed cMMP-14 did not appear. Approximately 0.5 mg purified cMMP-14 was obtained from 1 L of cell culture. Enzymatic kinetics tests using 1.5 nM of the purified periplasmic cMMP-14 and 1–40 μM fluorogenic peptide substrate indicated a k_{cat} of $5.48 \pm 0.08 \text{ sec}^{-1}$ and a K_{m} of $8.78 \pm 0.43 \mu\text{M}$ (Fig. 4), which were in excellent agreement with reported values (Neumann et al., 2004).

Evaluation of Inhibition Potency Using cMMP-14 Periplasmic Fractions

Encouraged by above results, we aimed to further demonstrate that human MMP-14 in crude periplasmic fractions can be directly applied for screening and evaluation of its inhibitors without purification of MMP-14. Serially diluted small compound or antibody-based inhibitors were added to the MMP-14 periplasmic fractions and incubated with the peptide substrate to monitor generated fluorescence signals. As results shown in Figure 5A, highly potent GM6001 and lowly potent acetohydroxamic acid (AHA) were

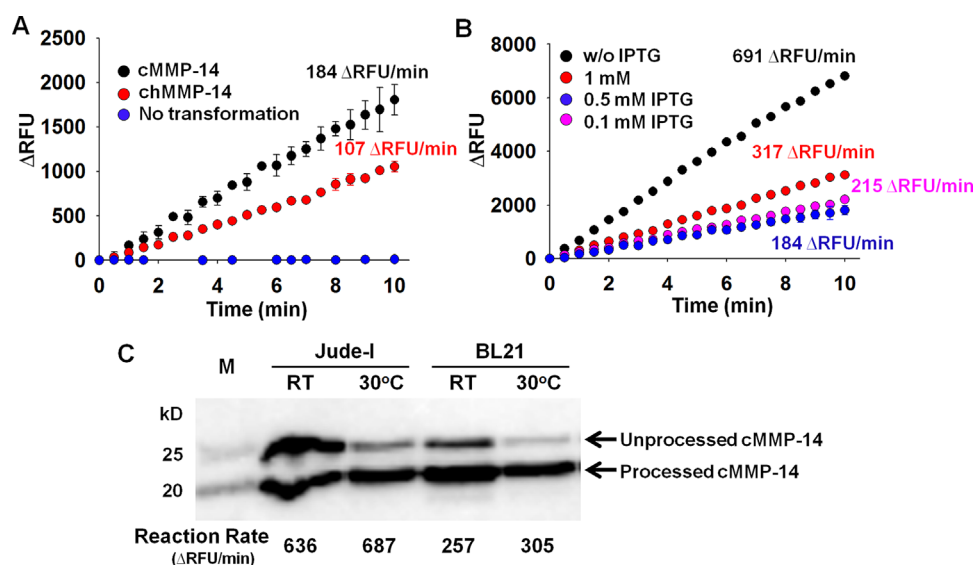

Figure 3. Periplasmic production of functional MMP-14 and expression condition optimization. (A) Activities of mature cMMP-14 and immature chMMP-14 in periplasmic fractions. (B) Effect of inducer IPTG concentration on cMMP-14 expression. (C) Host and temperature effects on cMMP-14 periplasmic expression assessed by western blot and FRET measurements. Same OD of cells was used for all the FRET measurements.

able to inhibit cMMP-14 activities in periplasmic fractions, with estimated IC_{50} s of 5 nM and 20 mM, respectively. In inhibitory antibody tests, Fabs of DX-2400 (Muruganandam et al., 2009), 3A2 and 3D9 (both isolated in our lab) exhibited dose-response behaviors towards cMMP-14 periplasmic fractions with expected high and moderate inhibition potencies (Fig. 5B), while the high affinity but non-inhibitory Fab 3B10 (produced by our lab) did not show inhibition. IC_{50} was measured as 10 nM for DX-2400 Fab, 30 nM for 3A2 Fab, and 90 nM for 3D9 Fab, which were consistent with our results measured by using MMP-14 refolded from inclusion bodies. Because this procedure did not require denature, purification, or refolding of MMP-14, it has the potential to greatly expedite characterization of inhibitors.

Simplify Inhibition Screening by Periplasmically Co-Expressing Fab and Human MMP-14

Our previous inhibitory antibody screening method required adding separately expressed and purified MMP-14 into the periplasmic preparations of potential antibody clones (Nam and Ge, 2013). Achieving periplasmic expression of functional human MMP-14 allowed us to simplify this screening approach by avoiding MMP-14 purification through periplasmic co-expression of both Fab and MMP-14. The pBR322 origin on MMP-14 expression plasmids was replaced with the p15A origin to make them compatible with Fab phagemids. After overnight culture of double transformed Jude-I cells, western blot results confirmed that periplasmic fractions contained Fabs (Fig. 6A). However, the initial FRET inhibition assay using cMMP-14 and a high potency Fab DX-2400 did not exhibit expected inhibition. Titration with GM6001 indicated the concentration of cMMP-14 in periplasmic fraction was 168 nM (based on three OD normalized cells in 200 μ L, Fig. 6B), plausibly too high to be efficiently blocked by co-expressed Fab, which present at a similar concentration (\sim 200 nM, estimated by western blot). To reduce enzymatic activity of MMP-14 in periplasmic fractions, chMMP-14 was chosen because it has less expression and activity compared to cMMP-14 (Figs. 3A and 6B). To further reduce the expression level of chMMP-14 which was under the control of a *lac* promoter, the concentration of suppressor, glucose, was optimized by GM6001 titration (Fig. 6B). Using chMMP-14 and the optimal 0.5% glucose, Fabs DX-2400, 3D9, 3A2 exhibited expected inhibition, while binding but non-inhibitory clone 3B10 and non-relevant clone A5A (anti-amylase) did not inhibit MMP-14 activity (Fig. 6C). Considering both the potency and expression level of the Fab contributed to the result of inhibition assays, this simple screening method without

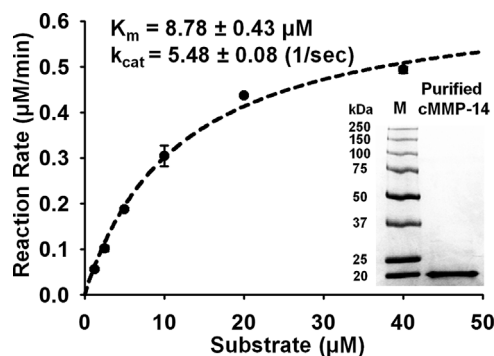

Figure 4. Enzymatic kinetics of cMMP-14 purified from periplasm and SDS-PAGE of purified cMMP-14 (inset). 1–40 μ M of FRET peptide Mca-Lys-Pro-Leu-Gly-Leu-Dap(Dnp)-Ala-Arg-NH₂ was used as the substrate to measure K_m and K_{cat} of cMMP-14.

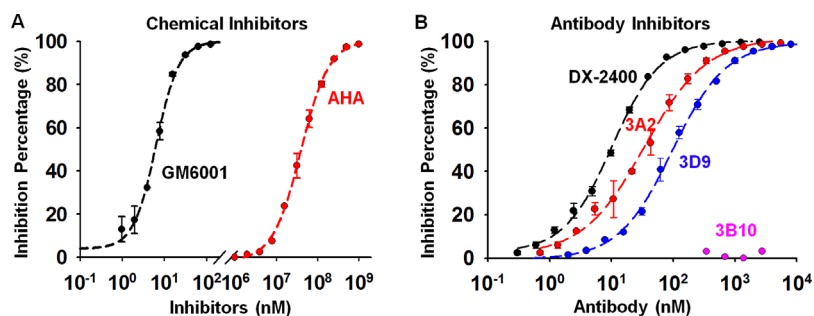

Figure 5. Semi-quantitative IC_{50} measurements using periplasmic fraction containing cMMP-14. (A) Inhibition profiles of chemical inhibitors GM6001 ($IC_{50} = 5$ nM) and AHA ($IC_{50} = 20$ nM). (B) Inhibition profiles of antibody-based inhibitors DX-2400 Fab ($IC_{50} = 10$ nM), 3A2 Fab ($IC_{50} = 30$ nM), 3D9 Fab ($IC_{50} = 90$ nM), and 3B10 (not inhibitory).

MMP-14 or Fab purification can be served as an initial and facile step to identify potential antibody inhibitors. This can be achieved by transformation of a Fab antibody library into cells carrying chMMP-14 and performing FRET inhibition assays after a rapid periplasmic preparation (Nam and Ge, 2013).

Discussion

As a membrane associated protease, human MMP-14 has been recognized as one of the most crucial MMPs in cancer development and metastasis. Therefore, the consistent supply of MMP-14 is critical for fundamental research and the development of MMP-14 specific inhibitors and antibodies for diagnostic and therapeutic purposes. Unfortunately, commercially available human MMP-14 is considerably expensive (often $> \$300$ per $10 \mu\text{g}$), and thus prohibitive to many biomedical research projects. Currently, the standard preparation of MMPs is through refolding of denatured MMPs from the inclusion bodies, which is a labor- and material-intensive and time-consuming process, usually associated with heterogeneous products. In distinct contrast to conventional approaches, this paper reports direct expression of active human MMP-14 in the periplasm of *E. coli*. By comparing immature chMMP-14 and mature cMMP-14, altering IPTG concentration, choosing host cells, and optimizing culture temperature, the activity of periplasmically expressed MMP-14 was significant

increased 6.5-folds from 107 to 691 $\Delta\text{RFU}/\text{min}$ (Fig. 3). To the best of our knowledge, it is the first reported study on direct expression of human MMP in the periplasmic space at its active format (Fig. 4). Although the productivity via periplasmic expression (0.5 mg/L) is considerably lower than that from refolding ($\sim 2 \text{ mg/L}$), the simple and straightforward approach without refolding or activation is more reliable with less lot-to-lot variation. This also provides a solid platform for the development of simple *in vitro* inhibition assays without MMP-14 purification. After a rapid periplasmic preparation (~ 15 min), inhibition potencies were accurately measured for a panel of chemical and antibody inhibitors, demonstrating that crude MMP-14 fractions worked well for inhibition assays. Co-expression of Fab and chMMP-14 further simplified the assay by avoiding the purification of Fabs. Therefore, phage panned or FACS enriched libraries can be cloned to cells harboring chMMP-14 plasmid to perform initial inhibition screening. This improvement is significant because this process does not need cloning, expression and purification of individual antibodies. In addition, co-expression of Fab and chMMP-14 also has the potential to develop a genetic selection method for inhibitory antibodies by incorporating a reporter substrate. We expect this periplasmic expression approach can be applied to other biomedically important MMPs as well, such as MMP-2 and -9. In these regards, the periplasmic expression of catalytic domain of MMPs and *in vivo* inhibition assays demonstrated in this paper provides an excellent approach to

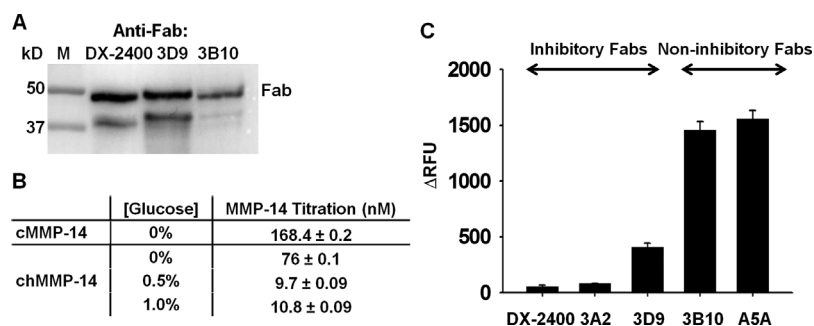

Figure 6. Periplasmic co-expression of MMP14 and Fabs for facile identification of inhibitory antibody clones. (A) Western blot showing the expression of a panel of Fabs in cells harboring the MMP-14 plasmid. (B) MMP-14 titration results when cultured with different concentrations of glucose. (C) Results of periplasmic co-expression FRET inhibition assays.

obtain functional MMPs alternative to the conventional refolding methods, and thus can be beneficial to the scientific community working on MMPs in general.

The financial supports from NSF (CBET 1453645) and UC Cancer Research Coordinating Committee are gratefully acknowledged.

References

- Babé LM, Linnevers CJ, Schmidt BF. 2000. Production of active mammalian and viral proteases in bacterial expression systems. *Biotechnol Genet Eng Rev* 17:213–252.
- Baneyx F, Mujacic M. 2004. Recombinant protein folding and misfolding in *Escherichia coli*. *Nat Biotechnol* 22:1399–1408.
- Cal S, López-Otín C. 2015. ADAMTS proteases and cancer. *Matrix Biol* 44–46:77–85
- Choi KY, Swierczewska M, Lee S, Chen X. 2012. Protease-activated drug development. *Theranostics* 2:156–178.
- Devy L, Dransfield DT. 2011. New strategies for the next generation of matrix-metalloproteinase inhibitors: selectively targeting membrane-anchored mmps with therapeutic antibodies. *Biochem Res Int* 2011: Article ID 191670, 11 pages.
- Durfee T, Nelson R, Baldwin S, Plunkett G, 3rd, Burland V, Mau B, Petrosino JF, Qin X, Muzny DM, Ayele M, Gibbs RA, Csörgo B, Pósfai G, Weinstock GM, Blattner FR. 2008. The complete genome sequence of *Escherichia coli* DH10B: insights into the biology of a laboratory workhorse. *J Bacteriol* 190:2597–2606.
- Dusing R, Sellers F. 2009. ACE inhibitors, angiotensin receptor blockers and direct renin inhibitors in combination: a review of their role after the ONTARGET trial. *Curr Med Res Opin* 25:2287–2301.
- Fernández ÁF, López-Otín C. 2015. The functional and pathologic relevance of autophagy proteases. *J Clin Invest* 125:33–41.
- Fernandez-Catalan C, Bode W, Huber R, Turk D, Calvete JJ, Lichte A, Tschesche H, Maskos K. 1998. Crystal structure of the complex formed by the membrane type 1-matrix metalloproteinase with the tissue inhibitor of metalloproteinases-2, the soluble progelatinase A receptor. *EMBO J* 17:5238–5248.
- Frenzel A, Hust M, Schirrmann T. 2013. Expression of recombinant antibodies. *Front Immunol* 4:217 (1–20).
- Genís L, Gálvez BG, Gonzalo P, Arroyo AG. 2006. MT1-MMP: universal or particular player in angiogenesis? *Cancer Metastasis Rev* 25:77–86.
- Goldman ER, Hayhurst A, Lingerfelt BM, Iverson BL, Georgiou G, Anderson GP. 2003. 2,4,6-Trinitrotoluene detection using recombinant antibodies. *J Environ Monit* 5:380–383.
- Gunnarsen KS, Lunde E, Kristiansen PE, Bogen B, Sandlie I, Løset GÅ. 2010. Periplasmic expression of soluble single chain T cell receptors is rescued by the chaperone FkpA. *BMC Biotechnol* 10:8.
- Harvey BR, Georgiou G, Hayhurst A, Jeong KJ, Iverson BL, Rogers GK. 2004. Anchored periplasmic expression, a versatile technology for the isolation of high-affinity antibodies from *Escherichia coli*-expressed libraries. *Proc Natl Acad Sci USA* 101:9193–9198.
- Hayhurst A, Happe S, Mabry R, Koch Z, Iverson BL, Georgiou G. 2003. Isolation and expression of recombinant antibody fragments to the biological warfare pathogen *Brucella melitensis*. *J Immunol Methods* 276:185–196.
- Jiang A, Lehti K, Wang X, Weiss SJ, Keski-Oja J, Pei D. 2001. Regulation of membrane-type matrix metalloproteinase 1 activity by dynamin-mediated endocytosis. *Proc Natl Acad Sci USA* 98:13693–13698.
- Knäuper V, Will H, López-Otín C, Smith B, Atkinson SJ, Stanton H, Hembry RM, Murphy G. 1996. Cellular mechanisms for human procollagenase-3 (MMP-13) activation. Evidence that MT1-MMP (MMP-14) and gelatinase A (MMP-2) are able to generate active enzyme. *J Biol Chem* 271:17124–17131.
- Koo HM, Kim JH, Hwang IK, Lee SJ, Kim TH, Rhee KH, Lee ST. 2002. Refolding of the catalytic and hinge domains of human MT1-mmp expressed in *Escherichia coli* and its characterization. *Mol Cells* 13:118–124.
- Lehti K, Valtanen H, Wickström SA, Lohi J, Keski-Oja J. 2000. Regulation of membrane-type-1 matrix metalloproteinase activity by its cytoplasmic domain. *J Biol Chem* 275:15006–15013.
- Lichte A, Kolkenbrock H, Tschesche H. 1996. The recombinant catalytic domain of membrane-type matrix metalloproteinase-1 (MT1-MMP) induces activation of progelatinase A and progelatinase A complexed with TIMP-2. *FEBS Lett* 397:277–282.
- López-Otín C, Matrisian LM. 2007. Emerging roles of proteases in tumour suppression. *Nat Rev Cancer* 7:800–808.
- Makino T, Skretas G, Kang TH, Georgiou G. 2011. Comprehensive engineering of *Escherichia coli* for enhanced expression of IgG antibodies. *Metab Eng* 13:241–251.
- Mimori K, Ueo H, Shirasaka C, Mori M. 2001. Clinical significance of MT1-MMP mRNA expression in breast cancer. *Oncol Rep* 8:401–430.
- Morrison CJ, Butler GS, Rodríguez D, Overall CM. 2009. Matrix metalloproteinase proteomics: substrates, targets, and therapy. *Curr Opin Cell Biol* 21:645–653.
- Muruganandam A, Tenhoor C, Devy L. 2009. Methods and compositions comprising anti-idiotypic antibodies and anti-MMP-14 antibodies. WO/2009/132251.
- Nam DH, Ge X. 2013. Development of periplasmic FRET-based screening method for protease inhibitory antibodies. *Biotechnol Bioeng* 110:2856–2864.
- Neumann U, Kubota H, Frei K, Ganu V, Leppert D. 2004. Characterization of Mca-Lys-Pro-Leu-Gly-Leu-Dpa-Ala-Arg-NH₂, a fluorogenic substrate with increased specificity constants for collagenases and tumor necrosis factor converting enzyme. *Anal Biochem* 328:166–173.
- Page-McCaw A, Ewald AJ, Werb Z. 2007. Matrix metalloproteinases and the regulation of tissue remodelling. *Nat Rev Mol Cell Biol* 8:221–233.
- Quirós PM, Langer T, López-Otín C. 2015. New roles for mitochondrial proteases in health, ageing and disease. *Nat Rev Mol Cell Biol* 16:345–359.
- Sela-Passwell N, Rosenblum G, Shoham T, Sagi I. 2010. Structural and functional bases for allosteric control of MMP activities: can it pave the path for selective inhibition? *Biochim Biophys Acta* 1803:29–38.
- Seiki M. 2003. Membrane-type 1 matrix metalloproteinase: a key enzyme for tumor invasion. *Cancer Lett* 194:1–11.
- Sroga GE, Dordick JS. 2002. A strategy for in vivo screening of subtilisin E reaction specificity in *E. coli* periplasm. *Biotechnol Bioeng* 78:761–769.
- Tetu B, Brisson J, Wang CS, Lapointe H, Beaudry G, Blanchette C, Trudel D. 2006. The influence of MMP-14, TIMP-2 and MMP-2 expression on breast cancer prognosis. *Breast Cancer Res* 8:R28.
- Trengove NJ, Stacey MC, MacAuley S, Bennett N, Gibson J, Burslem F, Murphy G, Schultz G. 1999. Analysis of the acute and chronic wound environments: the role of proteases and their inhibitors. *Wound Repair Regen* 7:442–452.
- Turk B. 2006. Targeting proteases: successes, failures and future prospects. *Nat Rev Drug Discov* 5:785–799.
- Udi Y, Fragai M, Grossman M, Mitternacht S, Arad-Yellin R, Calderone V, Melikian M, Toccafondi M, Berezovsky IN, Luchinat C, Sagi I. 2013. Unraveling hidden regulatory sites in structurally homologous metalloproteases. *J Mol Biol* 425:2330–2346.
- Wang X, Ma D, Keski-Oja J, Pei D. 2004. Co-recycling of MT1-MMP and MT3-MMP through the trans-Golgi network. Identification of DKV582 as a recycling signal. *J Biol Chem* 279:9331–9336.
- Ward ES. 1992. Secretion of T cell receptor fragments from recombinant *Escherichia coli* cells. *J Mol Biol* 224:885–890.
- Will H, Atkinson SJ, Butler GS, Smith B, Murphy G. 1996. The soluble catalytic domain of membrane type 1 matrix metalloproteinase cleaves the propeptide of progelatinase A and initiates autoproteolytic activation. Regulation by TIMP-2 and TIMP-3. *J Biol Chem* 271:17119–17123.
- Wülfing C, Plückthun A. 1994. Protein folding in the periplasm of *Escherichia coli*. *Mol Microbiol* 12:685–692.